

WARNING

If the filling is not done immediately:
ballast the tank with a minimum of 5 cm of liquid

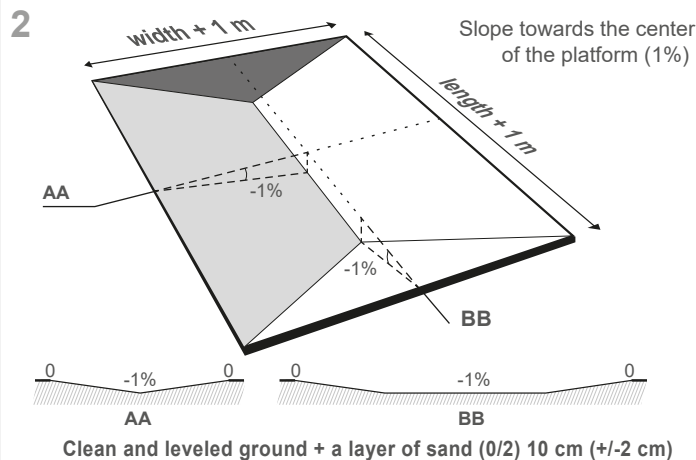

3 IMPORTANT
Installation of the tank according to its volume

V. (m ³)	Number of people
1 to 180	1 to 2
180 to 480	3 to 4
480 to 700	4 to 6
700 to 1200	6 to 8
> 1200	8 to 10

It is **strictly forbidden** to handle the product with machines to avoid any deterioration

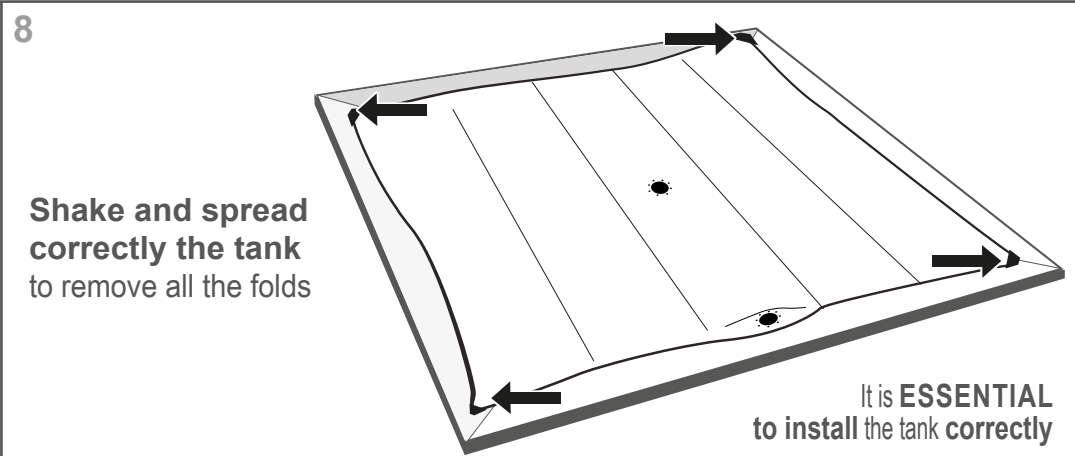
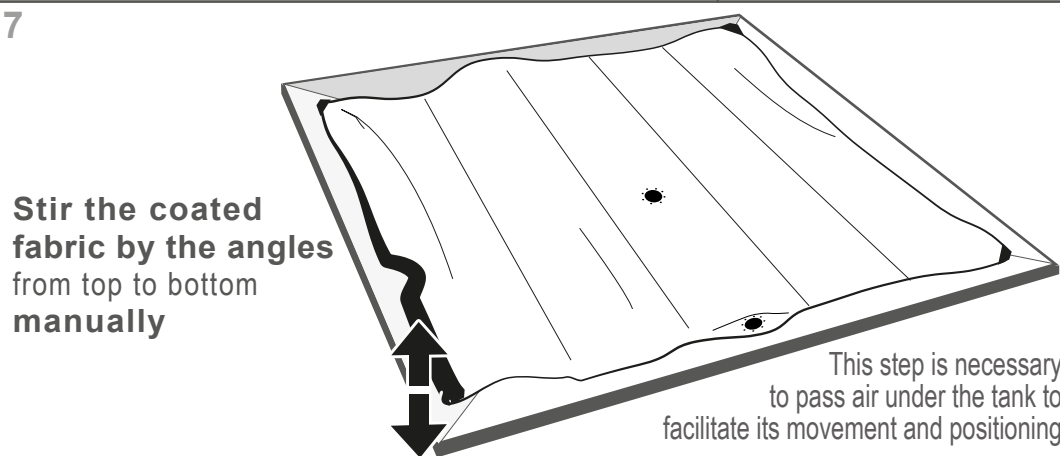
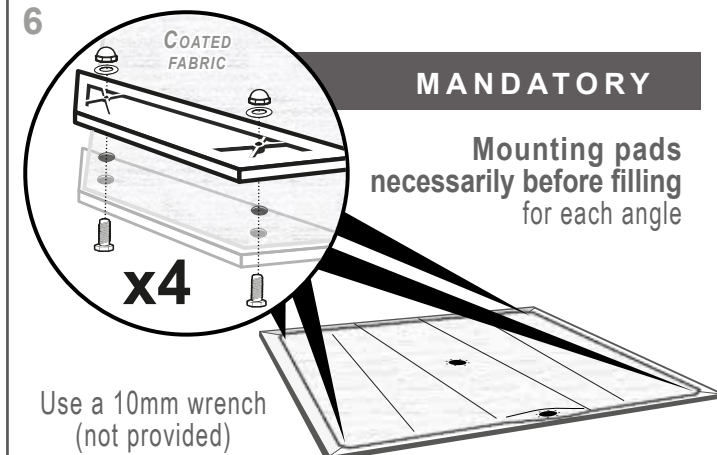
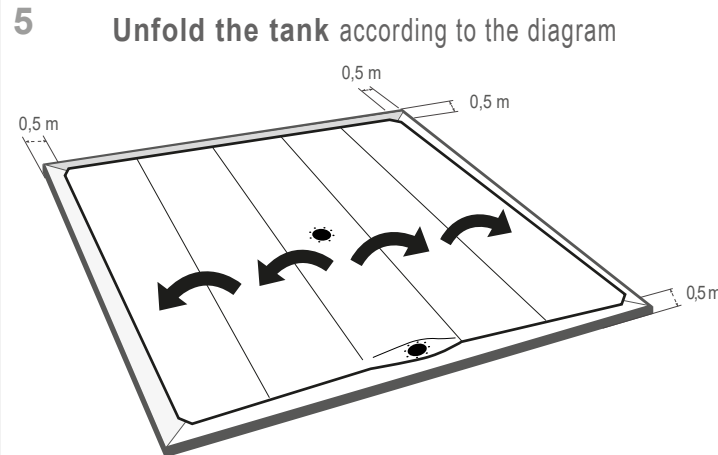
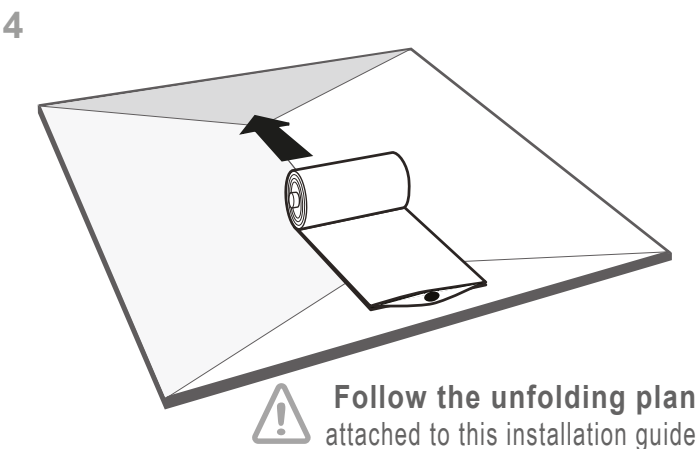



9 FOR ALL THE INLETS/OUTLETS

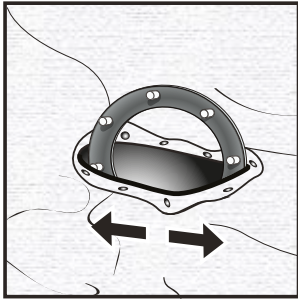

STRETCH WITH CARE
without tools, in order to pass
inside the counterflange with its seal

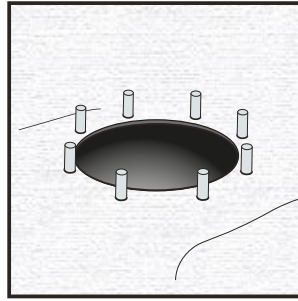

Install correctly the counterflange
in its socket

10 Use a 13mm wrench
(not provided)

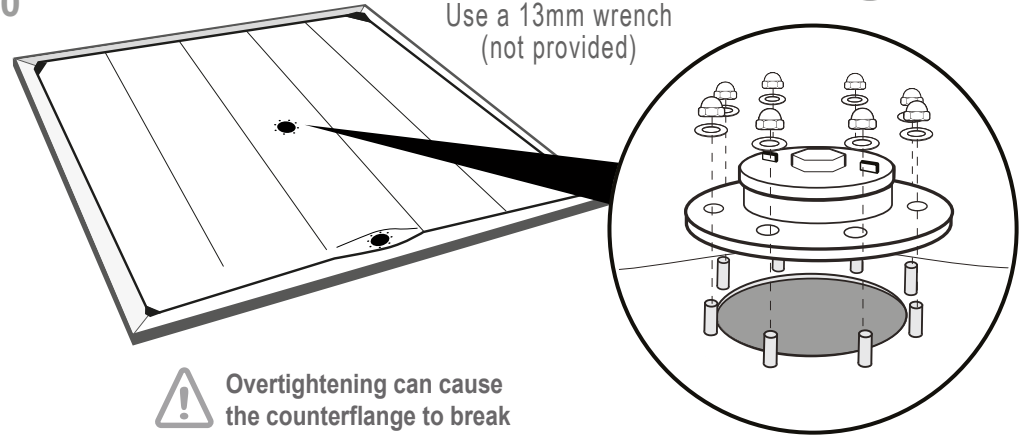

**! Overtightening can cause
the counterflange to break**

11 Use a 13mm wrench
(not provided)

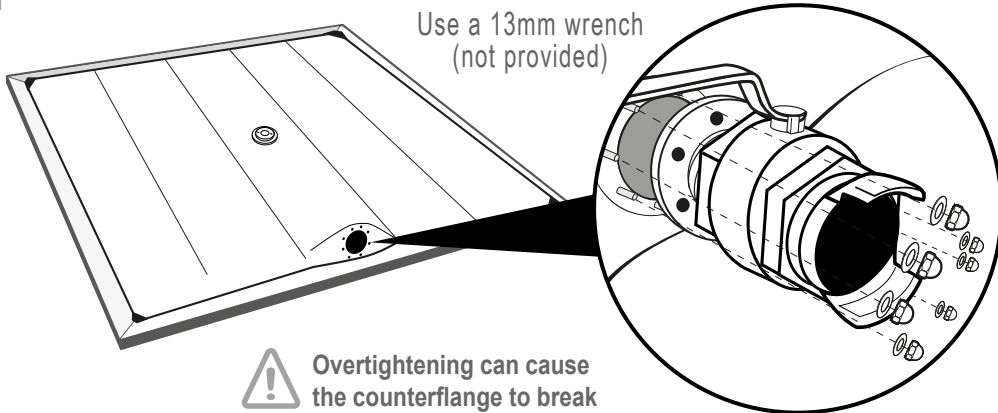

**! Overtightening can cause
the counterflange to break**

**12 ESSENTIAL STEPS
TO RENEW**

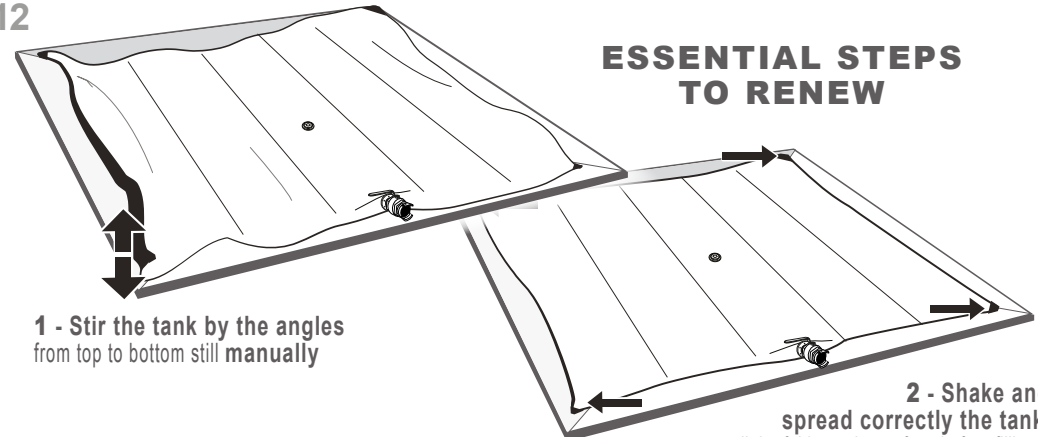

**1 - Stir the tank by the angles
from top to bottom still manually**

**2 - Shake and
spread correctly the tank:
remove all the folds on the surface before filling it**

13 Follow the instructions
for use

